

1:48 SHERMAN V M4A4 CONVERSION SET

Thank you for purchasing this conversion kit. It has been designed so that you can combine it with any of the Tamiya 1:48 scale Sherman kits to produce an accurate model of the M4A4 version. This type of tank was used almost exclusively by British and Commonwealth forces, and converted into many different versions including the famous 'Firefly', the Crab mine clearing vehicle, DD amphibious tanks, ARVs and others.

This kit includes cast resin parts for a complete new hull and smaller items cast in polyurethane resin, plus a sheet of photo etched brass for flat and delicate parts such as mud guards and brackets. You will need to purchase one of the Tamiya 1:48 Sherman kits to provide the turret, gun, hatches, wheels, tracks and smaller parts, which were common to most M4 variants.

For a standard M4A4, called the Sherman V in the British Army, we recommend the Tamiya M4A as it has all the pioneer tools moulded separately from the hull moulding. For the Sherman VC Firefly variant, you can use the Tamiya Sherman 1C kit or the Tamiya M4A1 plus a Firefly turret from MR Models. (www.mrmodellbau.de)

Please note, if modelling a 'Firefly', the Co-drivers position (right side) was taken up with spare ammunition racks, so the right hull hatch would usually be closed, and the periscope not used. The bow MG was removed and an armour plug welded in place. (Tamiya part G16)

There are several other manufacturers of accessory sets which would be suitable for additional detail parts, tools, machine guns, stowage and crew figures.

This conversion kit is aimed at the modeller who has some experience of building and detailing plastic scale model kits. We have been as careful as we can during the design and manufacture of these parts so you should not have any extra difficulty in assembling your M4A4, but please test the fit of parts before using any glue!

You will need adhesives capable of joining plastic to plastic (the Tamiya parts), PU resin to plastic (epoxy or slow set isocyanate glue) and metal to resin and plastic (fast isocyanate glue).

Normal modelling tools such as craft knife, files, sand paper, tweezers will all be very handy. There are several special tools for folding small etched brass parts, and while not being cheap to buy they are extremely useful.

Before assembly, check the cast resin parts. Sometimes, small bubbles form in the casting process and result in small holes in the surface of the part, usually on the corner of a detail. These can be easily filled with a smear of plastic filler, or for an even quicker job, a drop of thick Isocyanate glue can be persuaded into the hole and set hard with a spray of Activator. Any surplus glue can then be trimmed or sanded away.

We use a release agent in the moulding process, which should be removed before glueing or painting. A gentle scrub with an old tooth brush in tepid water with some washing up detergent will do the job, and a quick wipe with rubbing alcohol is very effective at removing finger marks after assembly prior to painting.

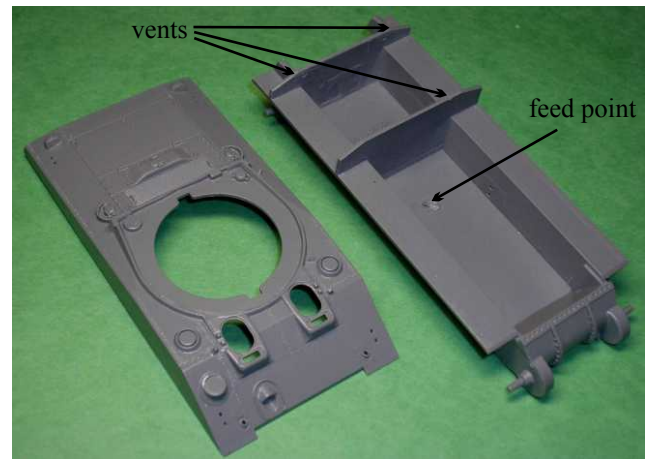

Cast resin hull top and bottom. Trim away any surplus material from the mould feed and vent points, and make sure the pieces fit together correctly.

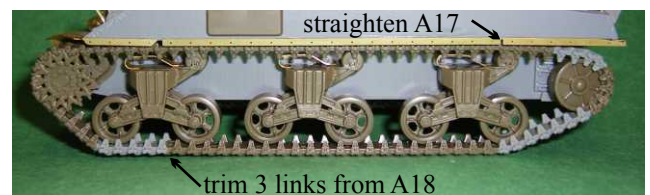

The parts for the bogies, wheels and tracks are taken straight from the Tamiya kit, with some modifications to the track, which was several links longer than a standard M4.

1. Attach the transmission covers (Tam part A16) over the sprocket axles; you will need to trim off the cover locating pins. Check the Tamiya instructions for exact location.
2. Assemble and attach the bogies and sprockets, making sure the sprockets can still rotate on their poly cap inserts. You can remove the over-scale bogie skids and replace them with the etched items included in the kit. These will need careful bending to the shape shown on page 4.
3. You will need to use 4 individual links on each sprocket, the same as in the Tamiya instructions.
4. You will need 4 links on the rear idler. This is ONE LESS than in the Tamiya instructions.
5. The top run of track (Tam part A17) will need straightening at its rear end; it is moulded with the last 4 links sloping down towards the idler. Rebend the last TWO links down, but only slightly!
6. For the bottom run of track, (Tam part A18), you need to trim away the FRONT three links and the FRONT three pairs of horns. The first front link is angled upwards slightly, just to make sure you get the correct end!
7. Then use the cast resin track lengths as follows:
 - 5 link length, under the front wheel of the front bogie.
 - 7 link length, from rear road wheel to idler.
 - 4 link length, from rear of top track to idler.Tamiya part A20 is used as in the kit instructions.

You may prefer to cut off the idler axle to allow the idler to find its own position when the track links are fitted. This will ensure there are no gaps between the links.

1:48 SHERMAN V M4A4 CONVERSION SET

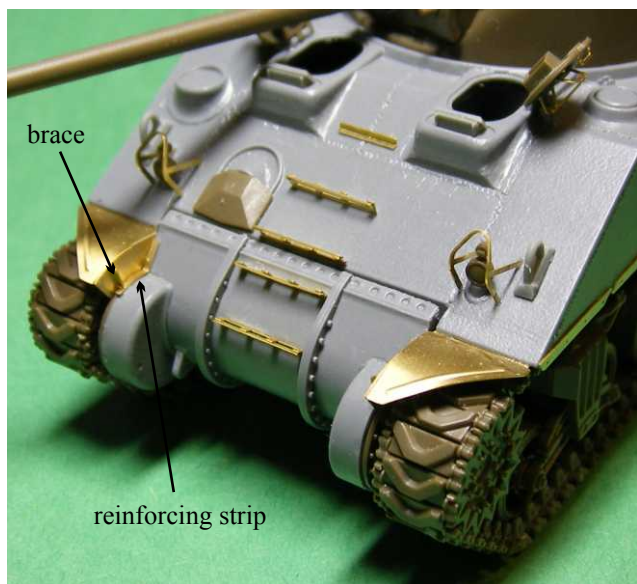

Brass parts are provided for the front mud guards and their reinforcing strips. Before cutting these parts from the frame, run an old ball point pen along the diagonal groove on the underside of the guards. This will raise a rib on the top surface, exactly as on the real thing. Carefully curve the guard over a suitable solid former; we used a small screw driver handle, but a pen or pencil will do as well. Fold the inner section so it matches the curved section and glue into place under the hull sponson front edge and on the transmission housing. The reinforcing strip is bent to match the shape of the glacis plate and transmission housing and glued, with its brace, as shown above.

The picture also shows the location of the headlight brush guards, spare track link frames and hatch periscope guards, and the cast resin lifting eyes. These replace Tamiya parts A13, having a rectangular base rather than being attached straight to the hull. Check your references, as these fittings varied from tank to tank.

Resin periscopes are provided for the driver and co-driver positions. Select open (angled cover) or closed (flat cover) and push these into the rectangular holes in front of the hatch openings. For Sherman V (75mm gun), both hatches and periscopes can be open if required. for Fireflies, (17 pdr) leave the right hatch and periscope closed!



This picture shows the location of the 'Firefly' bin and its etched lid. These were often to be found on other vehicles, and in different locations. Also shown are the rear mud guard mounting strips, smoke emitter boxes and rear light

brush guards. The smoke emitter boxes were sometimes fitted near the bottom of the engine door to allow the tow bar attachment to be used, otherwise they would clash. The tow bar, its two mounting plates and towing hook are provided in this kit as resin castings.

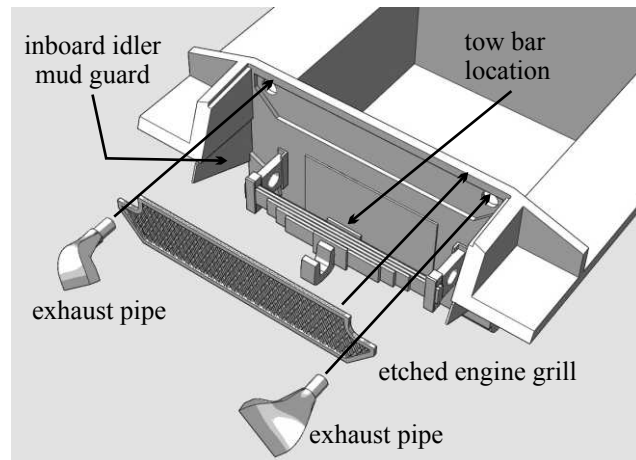

This sketch shows the locations of the etched engine grill and the inboard idler mud guards, the resin exhaust pipes and position of the tow bar assembly. Sometimes a curved exhaust deflector was mounted between the sponsons, this is provided as an etched part. Carefully curve (it is half-etched to help this) and glue as shown in the next picture.

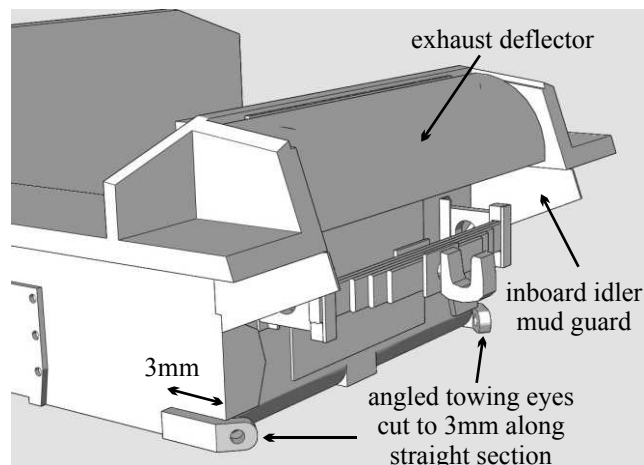

The resin parts include the two angled towing eyes that are glued to the hull sides below the idler mountings. Also provided are lifting eyes for the rear hull, mounted on pads in a similar fashion to the front lifting eyes. These replace Tamiya parts A14.

The turret, pioneer tools, fire extinguishers, applique armour, hatches, M2 .50 cal MG are all added from the Tamiya kit as appropriate for your model. A study of wartime photographs is highly recommended. Tank crews often piled on additional equipment, crates, jerry cans, ammo boxes, tarpaulins, camouflage netting, tree branches, ladders, bicycles and plenty more besides.

Most modellers have their own preferred sequence of assembly, to allow painting and weathering to be done easily. We suggest the hull top and bottom are not joined until most of the assembly and painting is done.

A few unit markings are available commercially as waterslide decals, but we are looking into adding some of these to our own range shortly, so please check our website www.fighting48th.com for more details.

1:48 SHERMAN V M4A4 CONVERSION SET

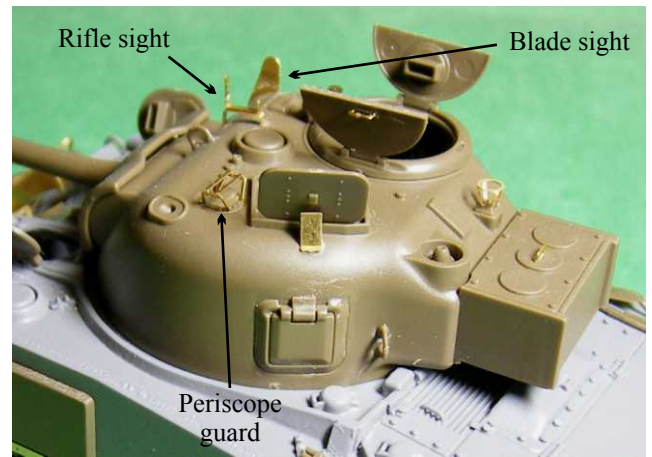
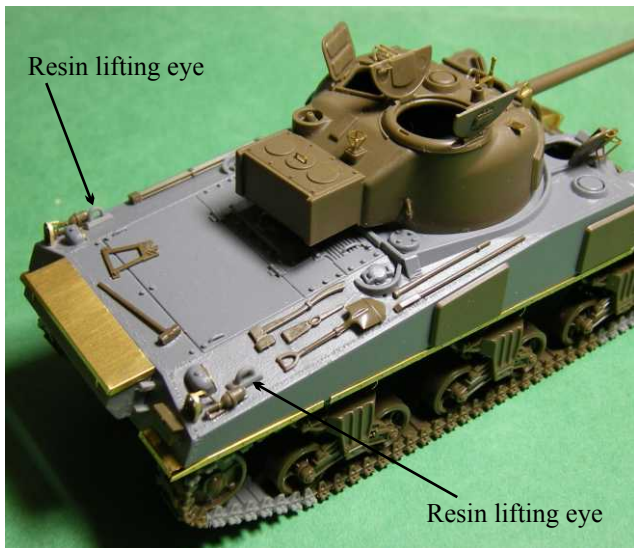

This picture shows the tools provided in the Tamiya M4A1 kit, while the turret and extinguishers are from the Tamiya Firefly IC model. Etched parts include the blade sight and 'rifle' sight, sun compass mount, aerial base guard, periscope guards and radio box handle, as well as the side dust guard mountings along the lower edge of the hull. These strips were often bent and broken by contact with walls and trees.

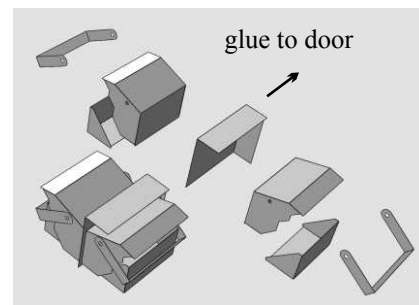

The next picture is a closer view of the Firefly turret, with the periscope guards, sights and loaders hatch support shown in more detail. Handles can be added to inside and outside of the hatches.

Here is the assembly of the smoke emitter boxes. The bracket is glued to the right rear engine door. When used, the lower tray hinges down to release the smoke candles.

PHOTO ETCHED PARTS

Photo etched parts are provided for a number of smaller fittings, brackets, mesh grills and thin sheet items such as the mud guards. Refer to the assembly photographs and diagrams for locations, but remember that these were often optional, were moved or altered by the soldiers operating the vehicles, damaged or shot away!

them from the frame when they are needed, otherwise you might lose them! Some items are folded to give a sharp corner, and these usually have a 'crease' etched into the reverse side. This makes sure the fold is in the right place. Other items need to be curved to shape. Use a small screw driver or drill bits of a suitable diameter. Brass is easy to form, and will allow you to adjust curved sections to get the correct shape. Parts can then be glued into place with isocyanate (Superglue) adhesives.

Photo etched parts are small, metal and sometimes have sharp edges, so please handle with great care. Only cut

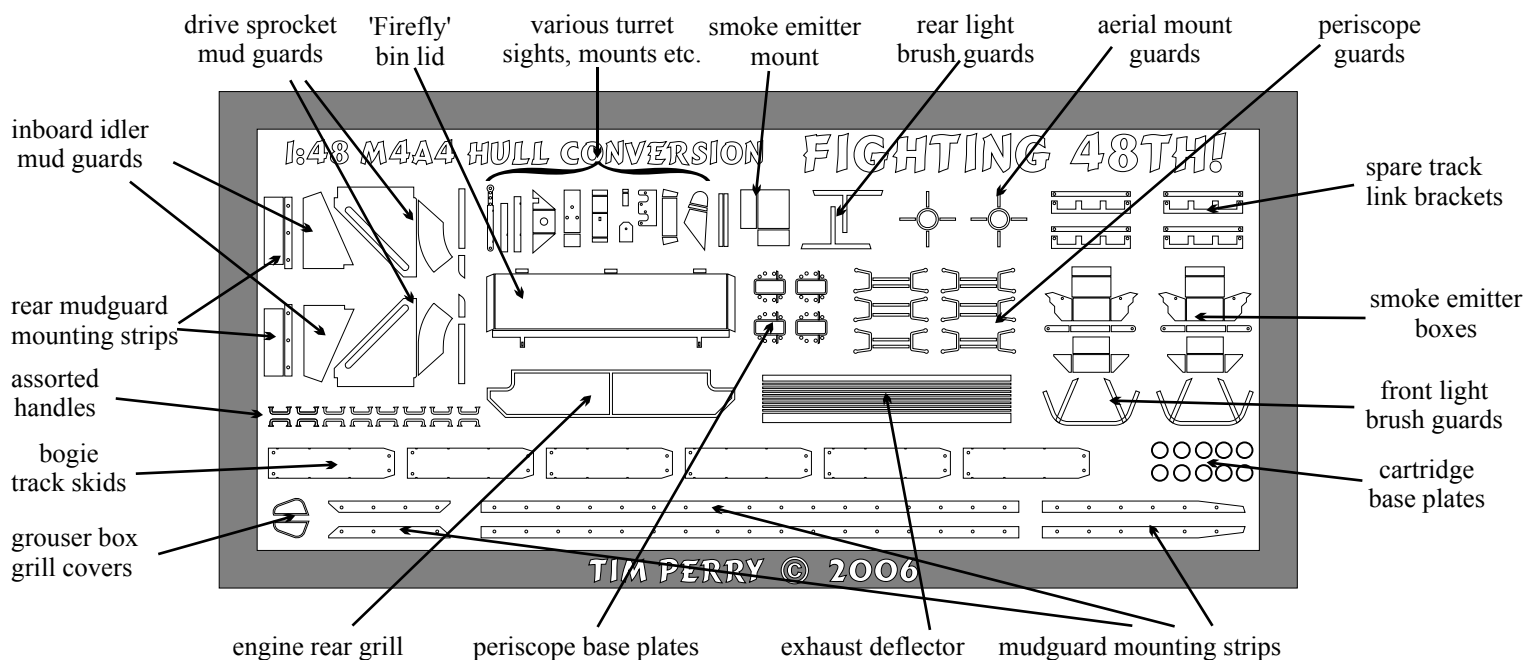

1:48 SHERMAN V M4A4 CONVERSION SET

CAST RESIN PARTS

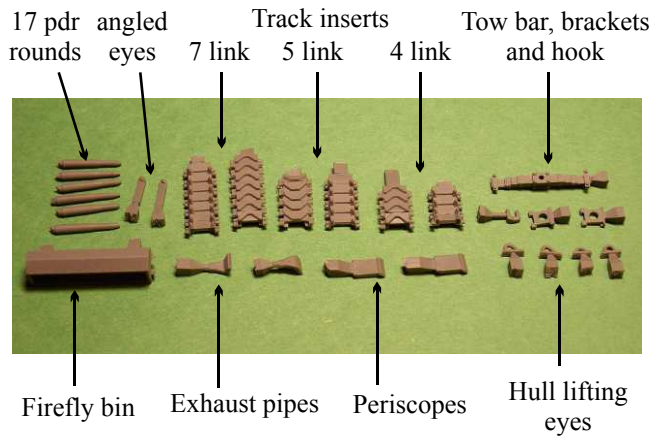

Here is a picture of the smaller resin parts supplied with the kit. The square or rectangular resin feed 'sprues' will need to be carefully cut away from each part, and any flash cleaned off. This is best done with a sharp craft knife. Wash the parts in water and detergent to remove any release agent before gluing or painting. The 17 pdr rounds could be used if you add some crew figures to your model. Cartridge bases are provided on the photo etched parts frame to improve the look of the cut end.

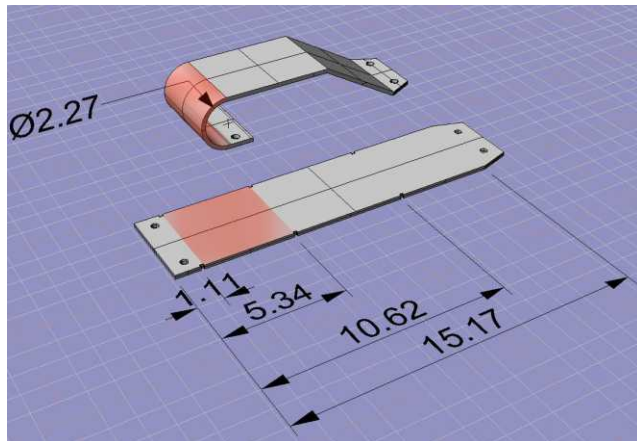

How to bend the the track skids. Dimensions are in mm. Use a small drill to form the curved section, and smooth faced pliers for the two creases.

ACKNOWLEDGEMENTS

If we have missed anything in these instructions, or you have a suggestion as to how this kit might be improved, do drop us a line. We will endeavor to incorporate these into the next production runs, as well as future kit projects.

While all the research, CAD work, pattern making, mould making and production have been done by myself, I would like to thank several others who kept me on track, provided advice and encouragement, and helped me greatly in getting this project off the ground.

Frank Berger, whose gentle and constructive criticism improved the final result wonderfully; Colin Alden, with all sorts of assistance, Alan Perry for proof reading these instructions, and finally my family who put up with books, magazines, smelly resin and sharp bits of metal all over 'their' PC and desk! Thanks to all of you!

Tim Perry, Bristol, November 2006

Copyright Tim Perry © 2006

REFERENCES

Over 7000 M4A4 tanks were built, most of which were used by the British and Commonwealth armies in Europe. Through the production run there were numerous developments, in addition to repairs and conversions carried out by the military units themselves. Because of this details vary from tank to tank, so for an accurate model the only way to be sure of your facts is to find a wartime photograph and make your model to match.

There are hundreds of books on the Sherman tank, its history and development but the following books proved invaluable to us and we are sure you will find them fascinating as well;

Sherman Firefly, Hayward, p. Barbarossa
Sherman Vc Firefly, Gawrych, p. Model Centrum Progres
British Tanks in Normandy, Fortrin, p. Histoire & Collections
British Tanks of WWII, Fletcher, (1 & 2) p. Concord
Military Modelling Magazine, vol 35 no 7
Military Modelling Magazine, vol 34 no 7

In this day and age the Internet has become a wonderful resource for the researcher. A quick 'Google' search using 'M4A4' or Sherman V' will turn up hundreds of potentially useful links. However, we would like to recommend www.track48.com as an excellent source of information specifically for the modeller in 1:48 scale, with plenty of reviews, hints and tips and a lively forum.

www.missing-lynx.com is another site aimed at the armour modeller, with a forum especially for 1:48 fans. Don't limit your visit to the forum though, there is plenty of valuable information elsewhere on the site.

If you can get to see a real M4A4, do so. Being based in the UK we have been able to view the exhibits at the Tank Museum, Bovington, Dorset, but if you cannot do this, the first two books on our recommended reading list will be the next best thing.

CONTACT & GUARANTEE

We want you to enjoy building this model project and ending up with an addition to your collection of which you can be proud. And of course, we would like you to buy the next project from us as well! This will be a conversion set to make a Sherman V Crab Mk1, incidentally.

If you have ANY problems, let us know immediately. We will always replace missing or broken parts. All of our products are backed with a money back guarantee. Provided the kit has not been started, send it back to us for a full refund.

So if there is something you don't like, TELL US!
If you loved the kit, TELL YOUR FRIENDS!

Fighting 48th!
9 Gadshill Drive
Bristol
BS34 8UU
United Kingdom

e-mail info@fighting48th.com
www.fighting48th.com for the latest news!